

2

1

B

B

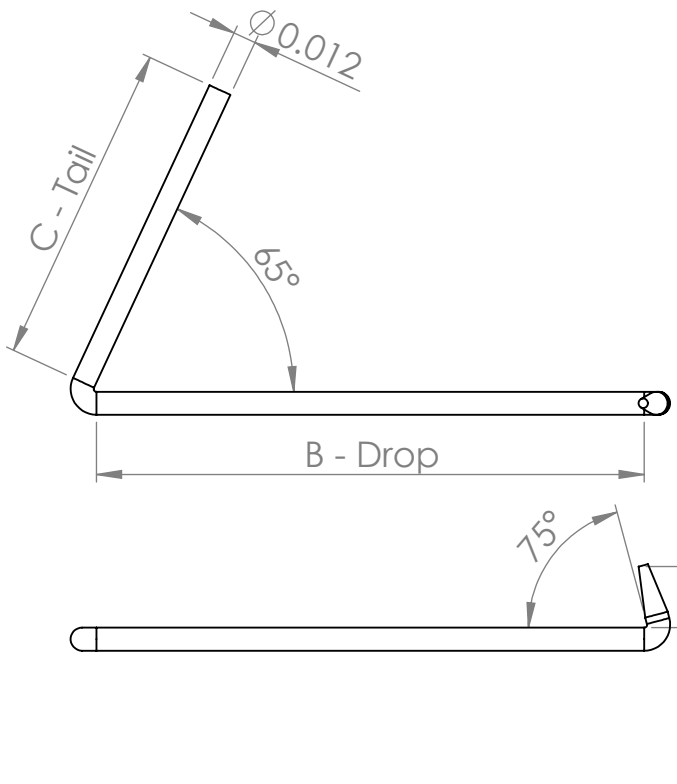

Model	Rec. Grams	A-Hook	B-Drop	C-Tail	D-Hook Dia.	E-Hook Taper
9101-10	5	0.010	0.30	0.18	0.003	0.170
9101-11	15	0.010	0.30	0.18	0.004	0.170
9101-12	30	0.012	0.30	0.18	0.005	0.195
9101-13	50	0.020	0.30	0.18	0.009	0.095
9101-18	150	0.020	0.30	0.18	0.012	0.130



A

A

PROPRIETARY AND CONFIDENTIAL
 THE INFORMATION CONTAINED IN THIS DRAWING IS THE SOLE PROPERTY OF American Probe & Technologies. ANY REPRODUCTION IN PART OR AS A WHOLE WITHOUT THE WRITTEN PERMISSION OF American Probe & Technologies IS PROHIBITED.

		UNLESS OTHERWISE SPECIFIED:		NAME	DATE
		DIMENSIONS ARE IN INCHES	DRAWN	DMC	3/4/22
		TOLERANCES:	CHECKED	KMC	3/4/22
		FRACTIONAL ±	ENG APPR.		
		ANGULAR: BEND ± 5 DEG	MFG APPR.		
		TWO PLACE DECIMAL ± 0.02	Q.A.		
		THREE PLACE DECIMAL ± .002	COMMENTS:		
		INTERPRET GEOMETRIC TOLERANCING PER:			
		MATERIAL TUNGSTEN WIRE			
NEXT ASSY	USED ON	FINISH LT MATTE FINISH			
APPLICATION		DO NOT SCALE DRAWING			

TITLE:		
SERIES: PH1		
SIZE	DWG. NO.	REV
A	9101-XX	A
SCALE: 10:1 WEIGHT:		SHEET 1 OF 1

2

1